



Inside CWM is published by Chicago White Metal Casting, and its CNC Technologies and Contract Manufacturing Divisions, for all of our employees and for our sales representatives and supplier partners who are equally vital to our success. Visit us at: www.cwmdiecast.com/ www.cnc-technology.com/ www.cwm-contractmfrg.com/
CWM is located near O'Hare Airport in Bensenville, IL U.S.A.

Committed to Total Customer Satisfaction
with CWM's ISO 9001 & ISO 14001 Registered
Management Systems: Excellence is Expected
 A GREEN BIZ COMPANY

Angela Favata Named '07 Employee of Year

Named Employee of the Month for July, Angela Favata's supreme multitasking abilities have led to her recognition as Employee of the Year and a \$1,000 award.



Angela Favata & Walter Treiber

Responsible for an array of administrative service activities, including finance, she is often the first contact customers have with CWM. Her informed guidance stands in contrast with the corporate voice mail maze often encountered at many companies.

Customers, suppliers and plant visitors all comment on Angela's cordial hospitality. ■

Higher Machining Speeds with New CNC Centers

Brian Andrews, V.P., CWM CNC Machining Division, announced the expansion of capacity with the installation of two Leadwell MV-40 CNC Machining Centers.

With 12,000 RPM spindles and 1280 IPM operation, the new units offer greater scheduling flexibility at higher machining speeds and precision. Larger table sizes and machine travel allows CWM to combine multiple operations: jobs previously requiring three machine setups can now be completed in a single setup. Larger castings can now be machined in house.

Recent introduction of a CWM-developed subplate system for CNC machines has also resulted in significantly reduced setup times. ■



21 Veterans Receive 10- to 30-year '07 Chicago White Metal Service Awards

Twenty-one CWMers were presented with awards for service at the company's 2007 Annual Awards Ceremony. Cash gifts for service terms ranging from 10 to 30 years, were presented by CEO Walter Treiber.

30 Year Service Honorees

Those honored for entering the 30-year mark were Dwight Hunt, Production Dept.; Virginia Hajlo, Finance Dept.; Zofia Skalska, Secondary Machining Dept.; and Ping Lau, Quality Assurance Dept.

25 Year Service Honorees

Honored were Trinidad Aguilera, Production Dept., Zygmunt Martynow, Production Dept., Jim Reitenbach, Production Dept., and Valerie Sekerka, Production Dept.

20 Year Service Honorees

Honored were Dave Crevie, Tool Room; Joseph Olszewski,

(Continued on page 2)



Dwight Hunt, 30 yrs.



Virginia Hajlo, 30 yrs.



Zofia Skalska, 30 yrs.



Ping Lau, 30 yrs.

Eric Treiber Appointed to Post of Chairman of NADCA's Government Affairs Committee

Eric Treiber, President and COO of CWM, has been named Chairman of the North American Die Casting Association's Government Affairs Committee, it was announced by Dan Twarog, President of NADCA.

Fostering Alliances for the Industry

On behalf of the entire die casting industry, this Committee is charged with aiding the fostering of strategic alliances with legislators in Washington and increasing the effectiveness of grassroots efforts of industry com-

panies in helping achieve a positive legislative agenda. Its current program is focussed on the importance of retaining a strong, competitive manufacturing base in the U.S.

Eric brings to his chairmanship a background in helping develop industry-wide relationships with the U.S. EPA, which included participation in the agency's Sustainable Industries Metalcasting Sector Program, plus the SF6 Emission Reduction Partnership for the Magnesium Industry. ■



21 Veterans Receive Their 10- to 30-year CWM 2007 Service Awards at Annual Ceremony

(Continued from page 1)

These CWM employees have been honored as Employees of the Month.

October '07: Valerie Sekerka (1982)
Cookie Sekerka performs superbly as a production team member, but her long commitment to CWM safety concerns has been equally important. She is also a tireless member of the Employee-of-the-Month committee. (This month her vote didn't count).



Valerie Sekerka

November '07: Eugene Thomas (1998)
Eugene, a member of the QA team, has enabled CWM to do all first-article inspections in house, as opposed to contracting those services to an outside source at a very high cost. Eugene's professionalism and positive attitude have won praise from his peers.



Eugene Thomas

December '07: Marisela Tamayo (2004)
Exemplifying poise, professionalism and excellence, Marisela Tamayo performs a variety of duties as Administrative Traffic Clerk. She is thorough in her follow-up and can always be relied upon to complete all projects assigned to her, with real multi-tasking abilities.



Marisela Tamayo

January '08: Casey Wisniowicz (1984)
Casey Wisniowicz, a member of the production department team, is tenacious in his dedication to improving cycle time and quality. He actively partners with the maintenance department to ensure customer requirements are consistently fulfilled. ■



Casey Wisniowicz

Maintenance Dept.; Anna Sral, Maintenance Dept.; and John Zientko, Maintenance Dept.

15 Year Service Honorees
Those honored were Maria Banas, Shipping/Quality Assurance Departments, Teresa Marchan, Secondary Machining Dept., and Efrain Ocampo, Production Dept.

10 Year Service Honorees

Honored were Fransico Acosta, Purchasing Dept.; Pablo Benitez, Production Dept.; Mary Cooper, Information Technology Dept.; Algie Crivens, QA Dept.; Melinda Gonzalez, Client Support; and Jose Ramos, Production Dept.

CWM employees, along with retired CWMers, were joined by suppliers and their representatives who all received special acknowledgment from Walter Treiber. Planning and arrangements for the ceremony and luncheon were made by Anne Andrews, Angela Favata, and Leonel Velazquez and his Maintenance Department crew. ■



Trinidad Aguilera, 25 yrs.



Zygmunt Martynow, 25 yrs.



Jim Reitenbach, 25 yrs.



Valerie (Cookie) Sekerka, 25 yrs.



Dave Crevie, 20 yrs.



Joseph Olszewski, 20 yrs.

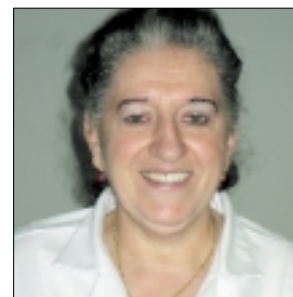

Anna Sral, 20 yrs.



John Zientko, 20 yrs.



Maria Banas, 15 yrs.



Maria Teresa Marchan, 15 yrs.



Efrain Ocampo, 15 yrs.

CWM Receives the 2007 Corporate Award from the Rehabilitation Institute of Chicago

By implementing a plan to help an employee transition back into the working world after a stroke, Chicago White Metal has earned a "2007 Corporate Award" from the prestigious Rehabilitation Institute of Chicago, which is dedicated to helping people with physical disabilities live a fulfilling life.



Anne Andrews (left), CWM Human Resources Mgr., accepting the RIC's 2007 Corporate Award from Christina Bard, Director, Vocational Rehabilitation, RIC.

"We needed to work with his rehabilitation case worker to closely monitor his work schedules, workload and overall physical condition," according to Anne Andrews, newly appointed CWM Human Resources Manager. "We did this with the

guidance of his direct supervisor and the managers of two CWM departments where he was working to determine what the best permanent fit would be for him at Chicago White Metal Casting." ■

CWM Ad Scores High Reader Impact Rating

A CWM full-page color ad in the August 13 Design News "Materials" Supplement received outstanding performance ratings among engineer readers in the "Message Impact" study conducted by the independent Readex Survey Research organization.

CWM's Topcon Housing ad, below, was one of 16 full-page ads in the Supplement and scored above average for all ads. When ratings of four comparable advertisers (of either die castings or plastics) were compared, CWM scored 15% higher than the average of the other three on "Information Value" & 10% higher on "Believability."

Among engineer readers asked whether they "took" or "plan" one or more actions after reading the ad, the percent indicating an



A Look at the Die Casting Industry's Last 50 Years

In the recent 50th Anniversary issue of *Die Casting Engineer*, official industry publication of the North American Die Casting Assn., Walter Treiber was asked to look back at the industry's last 50 years. His comments are excerpted here.

Having spent 48 years full-time, and another 8 years of exposure as a youngster, I find this industry as exciting today as when I started full time in 1959. Taking designers' and customers' ideas in the design stage, contributing significant engineering guidance, and turning those ideas into reality in metal has been very soul rewarding.



CEO Walter Treiber

What also has not changed in the past 50 years is the die casting industry's quest to produce better parts—through closer tolerances, thinner walls, denser castings and new alloys.

A significant and growing change that I have witnessed is an unrelenting demand for lower component pricing, at the same time that part complexities have increased and more challenging shapes and critical tolerance requirements have multiplied.

Asked to look into the future, through a crystal ball made of metal, I see futuristic alloys combining metal, plastic and other lightweight materials that can be cast in unique shapes never before possible.

In retrospect my most rewarding experience has been the growth of the people at Chicago White Metal Casting; many have spent their entire lives working at the company, with their second and third generation offspring here as well. We just celebrated the company's 70th year, with my own family's third generation now also at CWM. ■

action taken or planned was 50% higher for CWM's ad compared to the average of the other three advertisers and 47% more Design News readers said of CWM's ad that they would "visit the advertiser's website." ■

New CWM QA Planning Manager: Sylvia Garcia

Sylvia Garcia has been appointed to the new position of CWM's QA Planning Manager, it was announced by Bill Baraglia, VP, Manufacturing. She will be responsible for establishing dimensional appraisal procedures which will, by providing more timely feedback, help improve product quality and reliability.



Sylvia Garcia

Sylvia brings significant experience to the new position, including 14 years in all quality departments at an automotive metal stamping company in Elk Grove, eventually becoming Quality Mgr. Asked to relocate with the company to Kentucky, she declined, preferring to stay in the Chicago area.

She lives with her daughter Jiselle, 11, and a miniature pinscher, Chewy, in a home she purchased next to her mom. ■

Jody Scollard Carries the CWM Flag in Southeast

Jody Scollard brings a solid background in mechanical engineering to his regional sales manager position with CWM in the Southeast (NC, SC, GA, FL, AL, MS, TN).

Jody joined CWM late in '06, after leaving Dynacast as regional sales engineer when they closed their SC facility. Before honing his technical sales skills developing a successful territory for Dynacast, he was engineering manager for the Fuel System Group of Siemens in Virginia. He was part of Siemens engineering for 8 years, after receiving his M.E. degree from Auburn.

His first move after Dynacast, he states, was a call to CWM due to its fine reputation. Prospects for '08: Exciting.

Jody and Christa have been married almost 13 years and live in Alpharetta, GA with three handsome dogs. ■

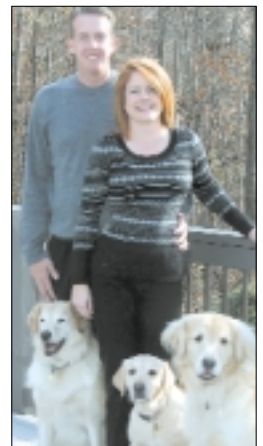

Jody Scollard and Christa, and their two golden retrievers and a golden lab mix.

How CWM makes the highest quality die cast part at the lowest unit cost

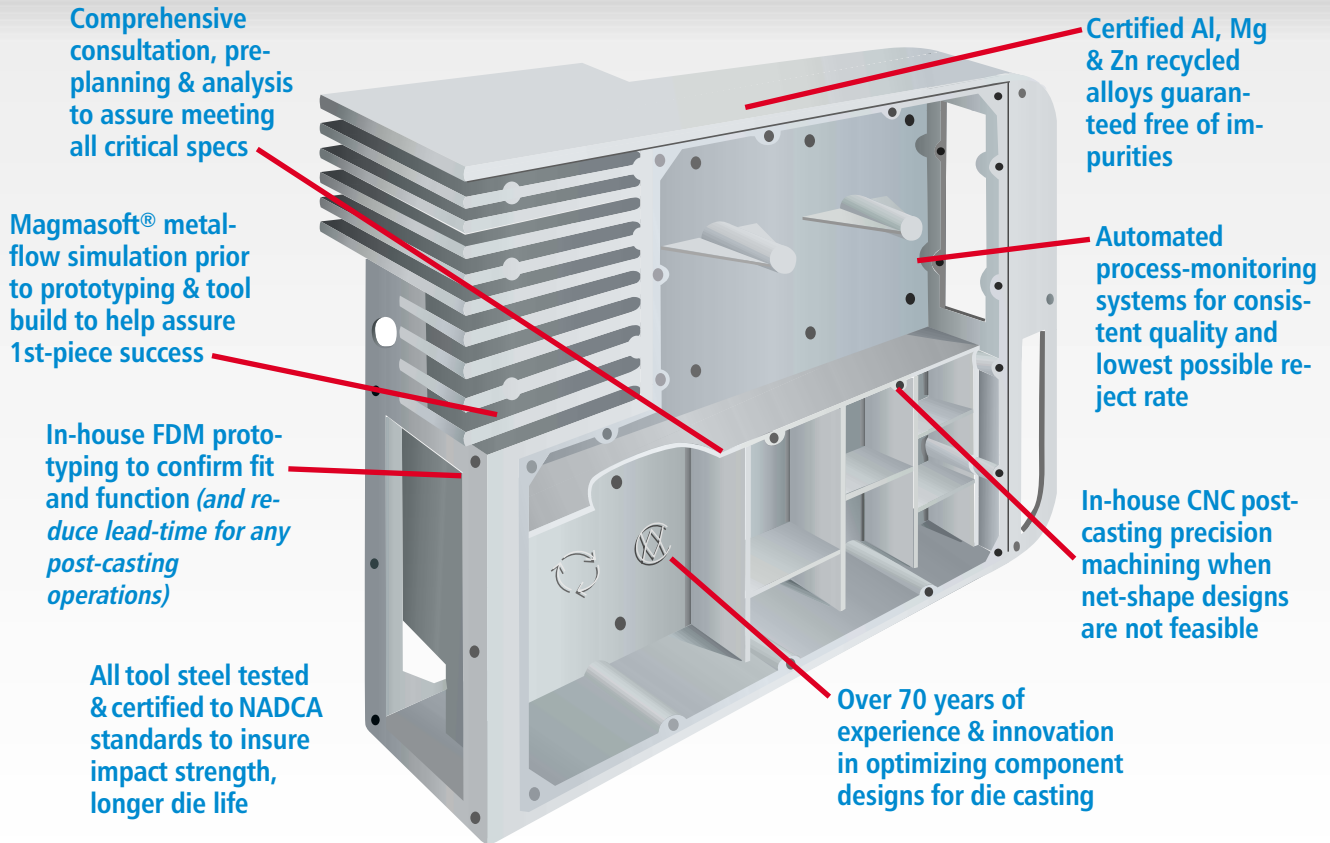

Recent Example



Critical specs, stiffness, light weight

Following prototyping, hot-chamber Mg die casting was chosen for volume production for two medical imager housing sidewalls. Reasons: process stability of die casting and mag's stiffness, light weight and ability to meet critical specs.

Download the details, 1 of 60 PDF aids

The case study, released by permission, is just one of over 60 design and speci-

fication guides for OEM product designers from CWM's Web Resources. For details on this example and downloading the study, plus all OEM design and spec guide listings, go to:

www.cwm-lit.info/wr19

Also visit our website (below) for more on CWM's complete capabilities and the location of your regional CWM Sales-Engineering Representative.

Certified Aluminum,
Magnesium & Zinc
Die Casting and
Miniature Zn/ZA-8

EXCELLENCE IS
EXPECTED



A GREEN BIZ
COMPANY

**Chicago
White Metal
Casting, Inc.**



ISO 9001 Certified Quality Management System
ISO 14001 Certified Environmental Management System

649 North Route 83, Bensenville, IL 60106
Phone: 1-630-595-4424 Fax: 1-630-595-9160

www.cwmdiecast.com